

SMĚR LET DŘEVA



MIKY

ROZPĚTÍ: 270 mm
 DÉLKA: 310 mm
 HMOTNOST: 10 g



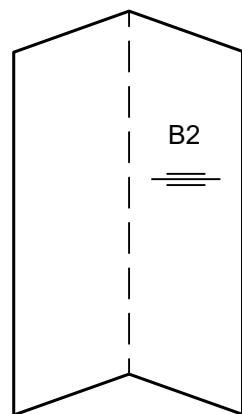
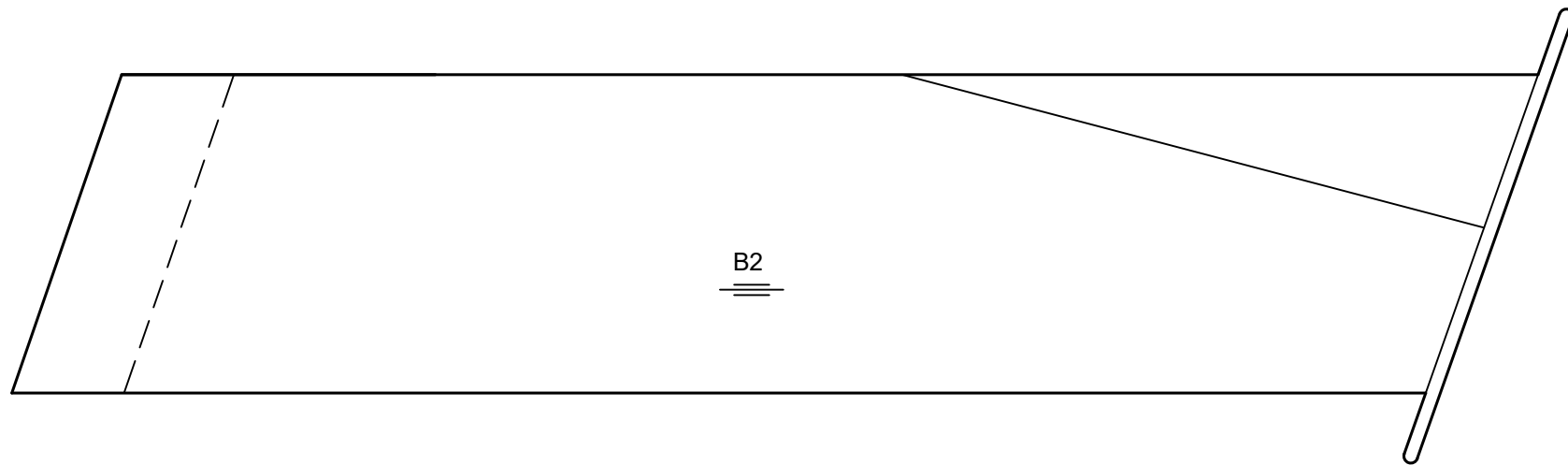
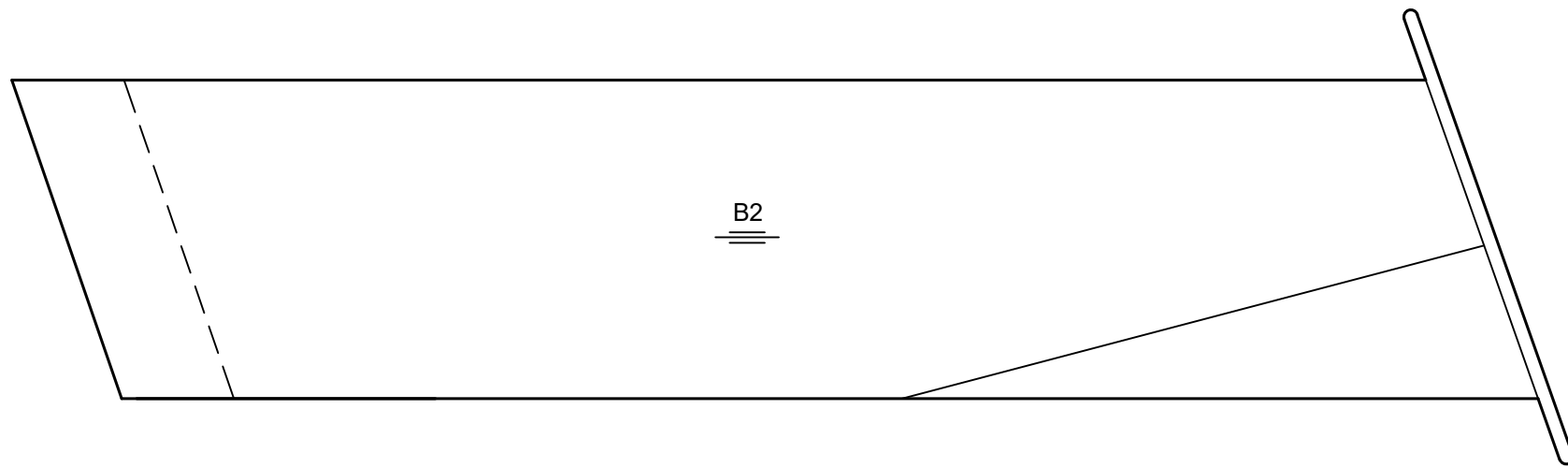

ZESÍLENÍ SPOJE KŘÍDLA

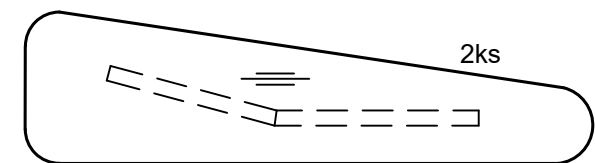
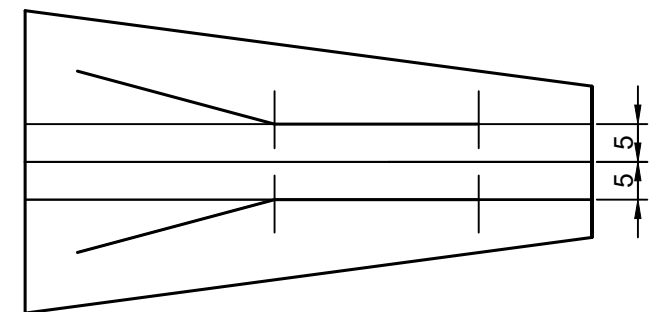
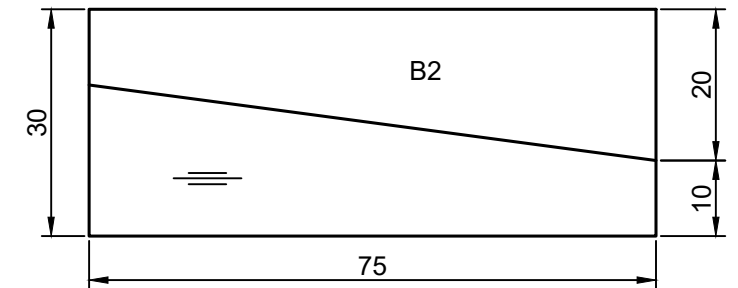
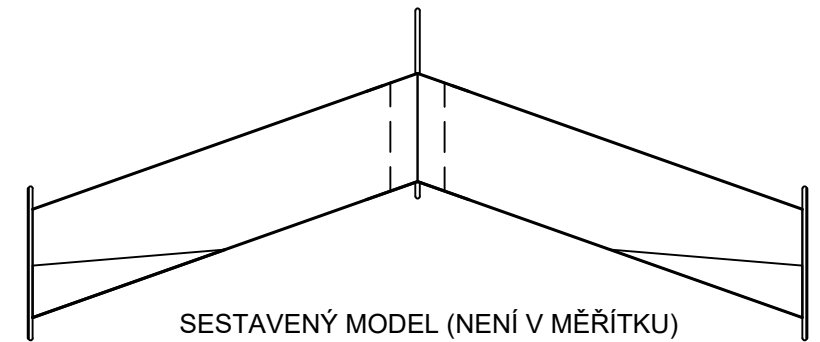
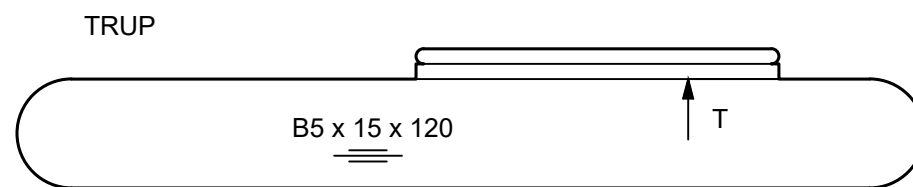

SMĚR LET DŘEVA 

VÍTEK

SAMOKŘÍDLO

ROZPĚTÍ: 380 mm
DÉLKA: 120 mm
HMOTNOST: 11 g



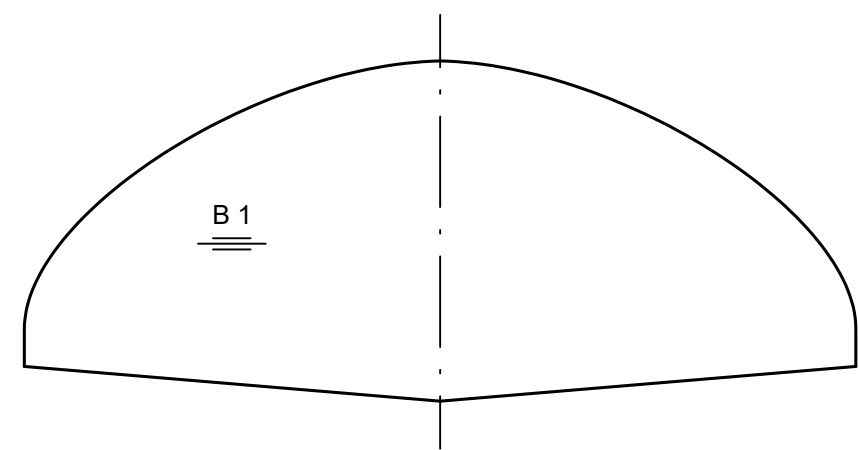
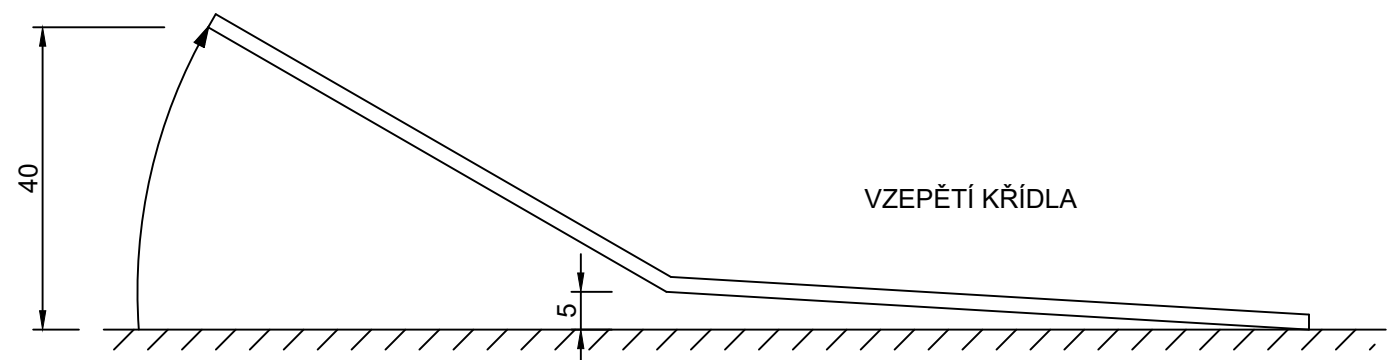
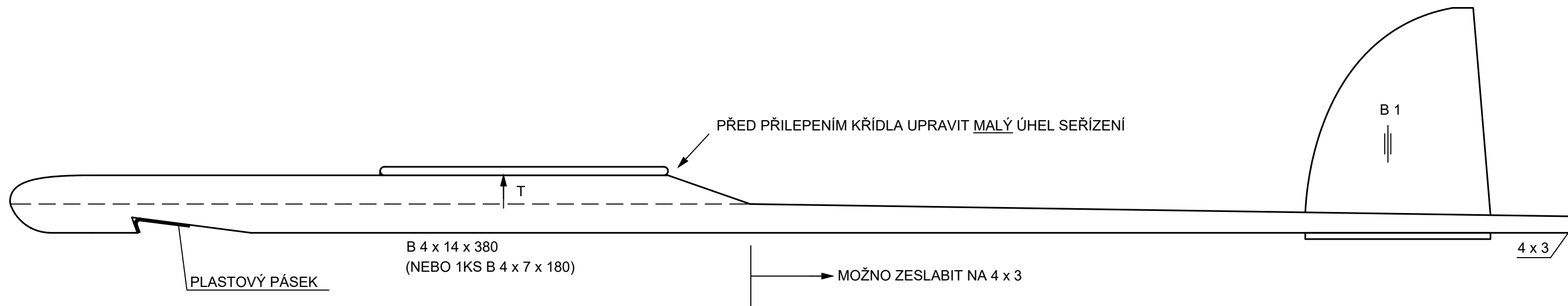

SMĚR LET DŘEVA 

PIFÍK

ROZPĚTÍ: 290 mm
 DÉLKA: 380 mm
 HMOTNOST: 13 g



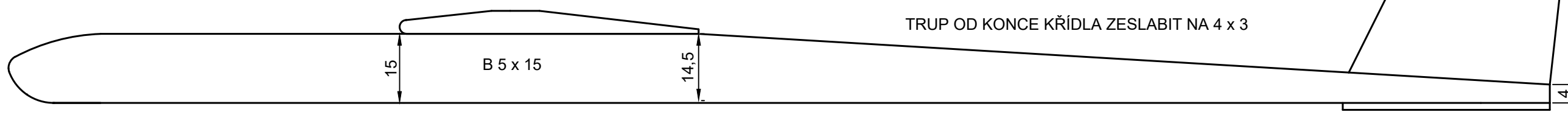
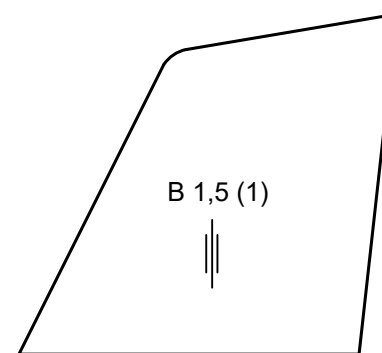
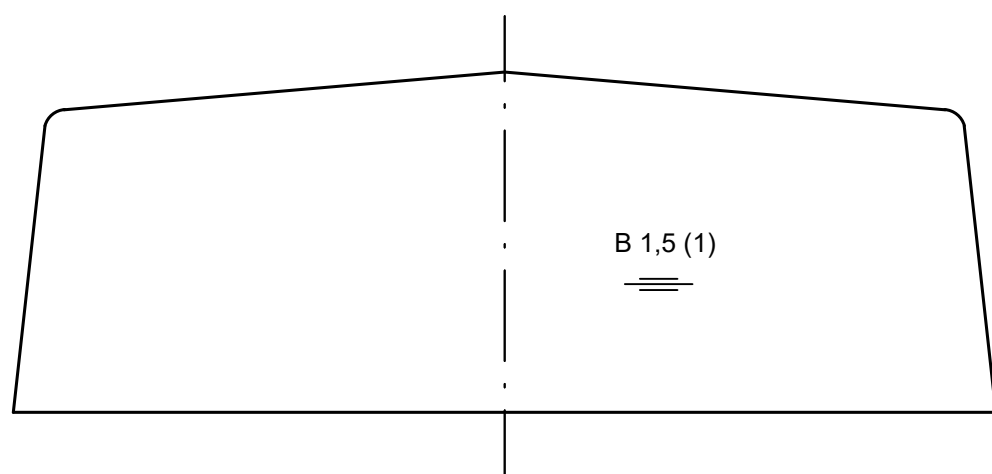
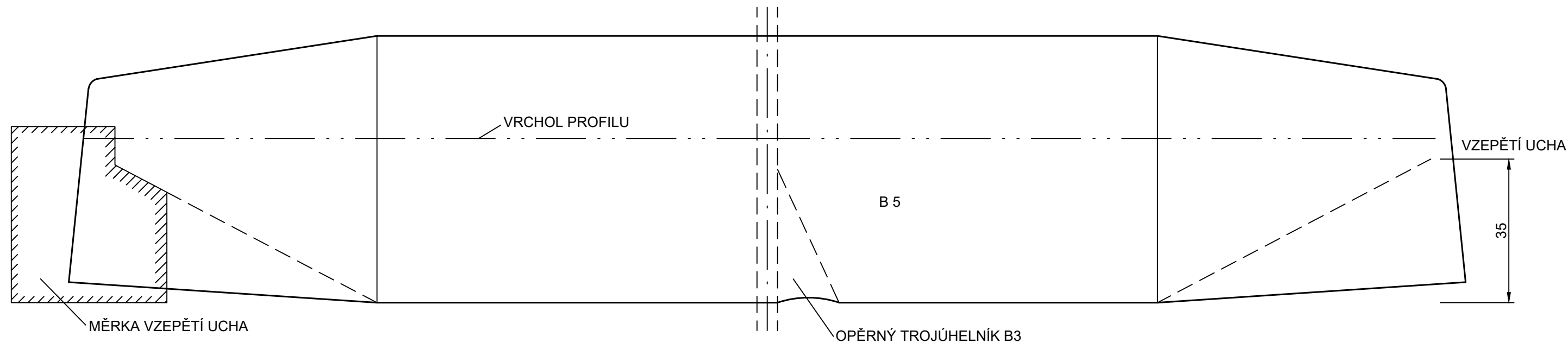

PROFIL KŘÍDLA M 2:1

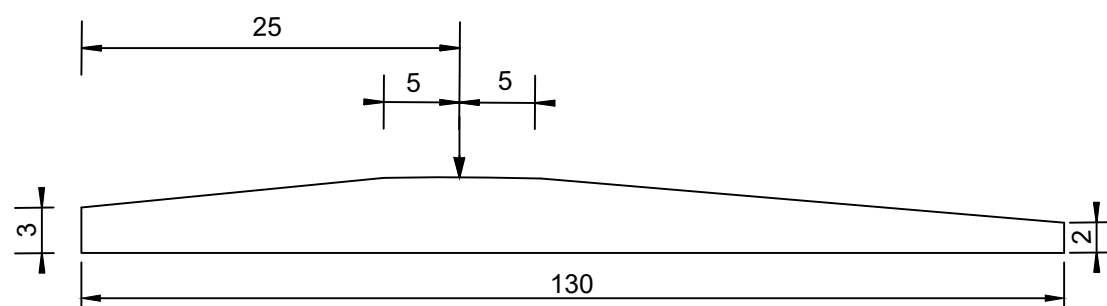

SMĚR LET DŘEVA

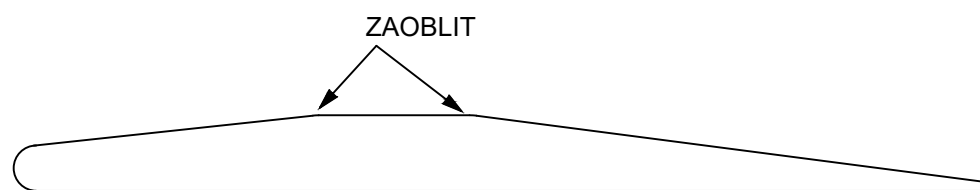

DAN

ROZPĚTÍ: 320 mm
 DÉLKA: 335 mm
 HMOTNOST: 22 g



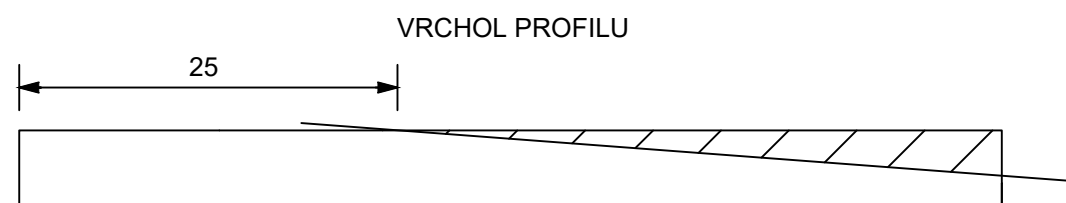
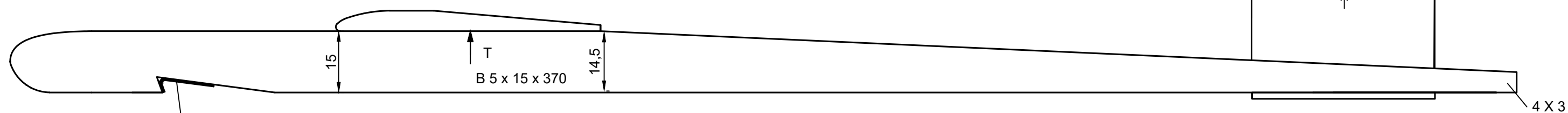
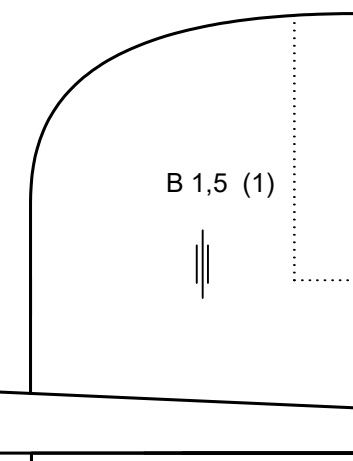
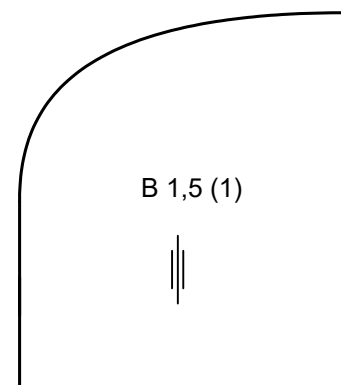
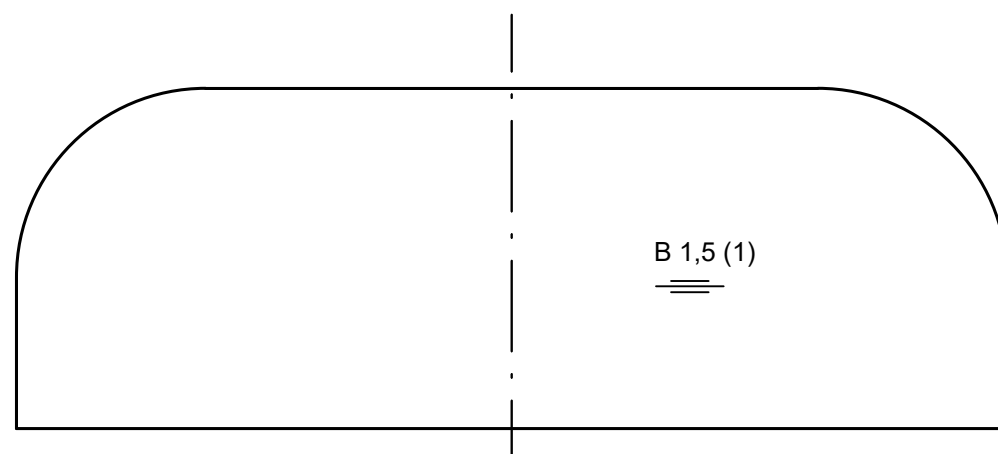
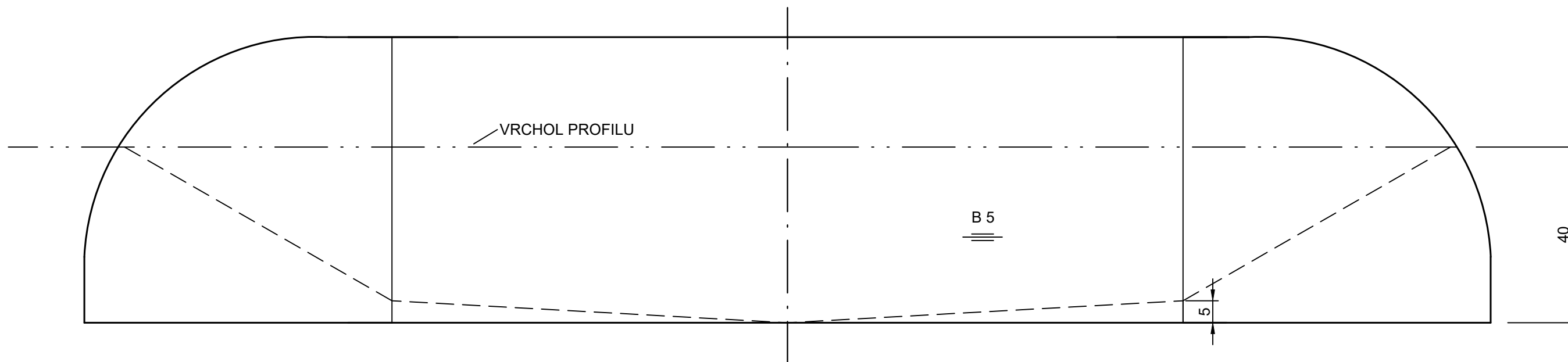

POSTUPNÉ ZHOTOVENÍ PROFILU KŘÍDLA M 2:1



KONEČNÝ TVAR PROFILU

BEN

ROZPĚTÍ: 300 mm
 DÉLKA: 370 mm
 HMOTNOST: 26 g



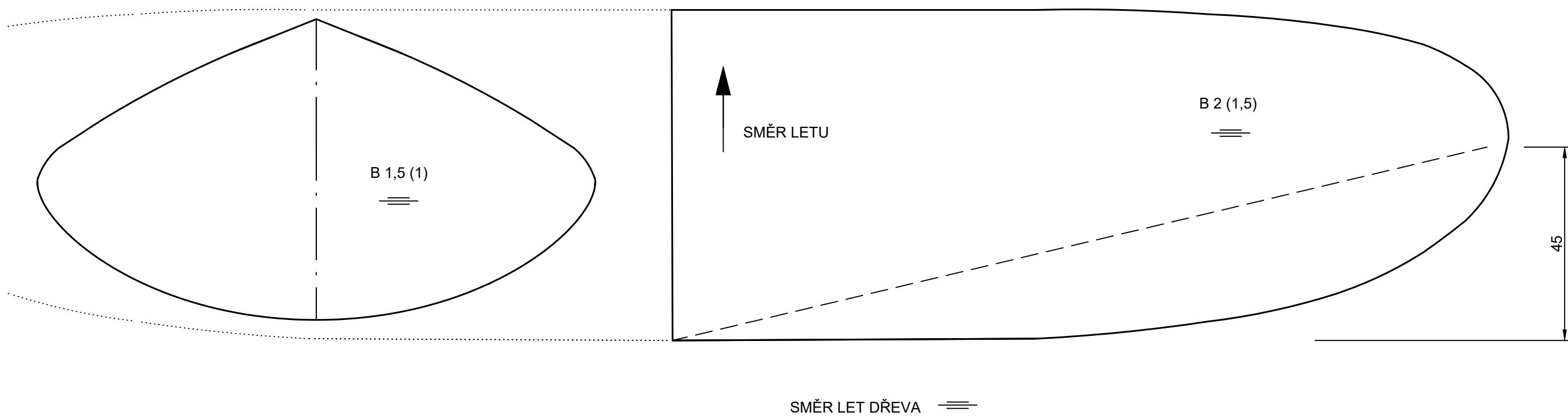
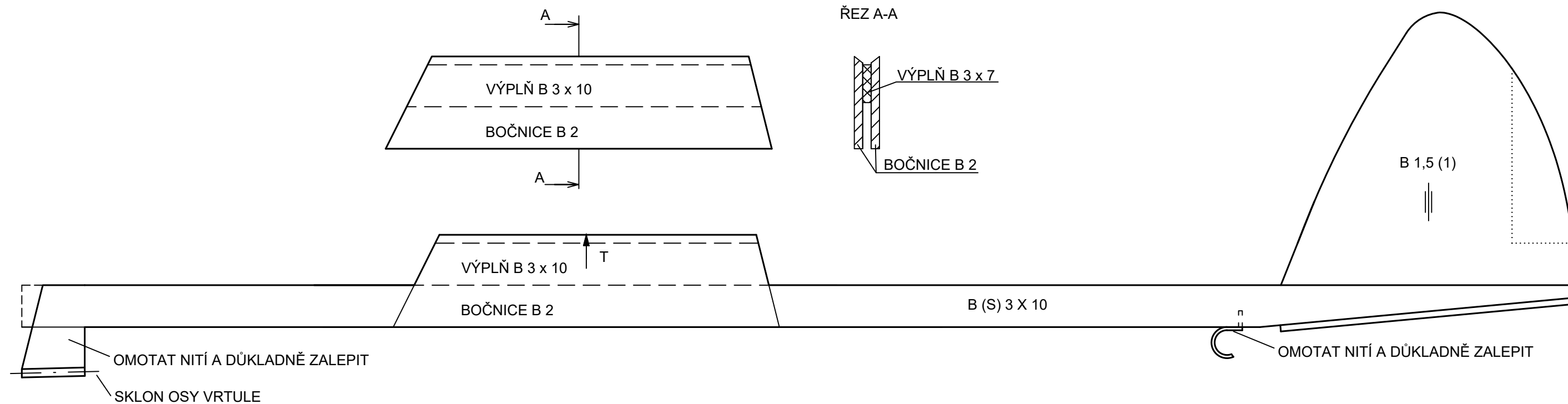

VRTULE:

- PLASTOVÁ Ø150
- NEBO KOMPLET Z MODELU KOMÁR

GUMÍK

ROZPĚTÍ: 390 mm
 DÉLKA: 370 mm
 HMOTNOST: 21 g



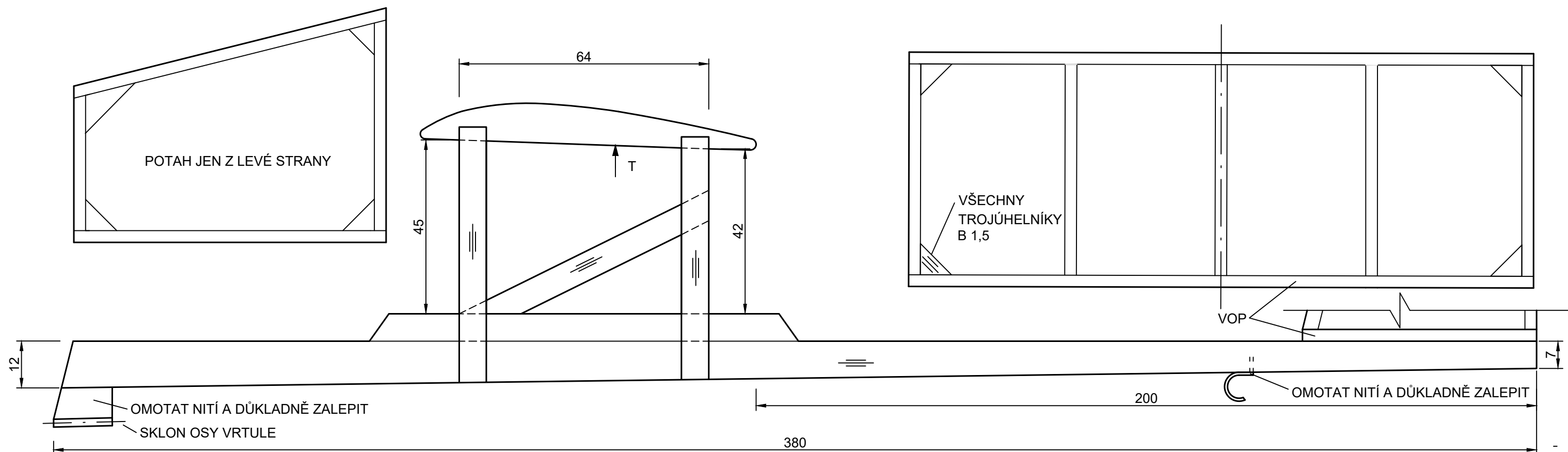

SMĚR LET DŘEVA
 VŠECHNY DÍLY ZHOTOVENY Z B 3

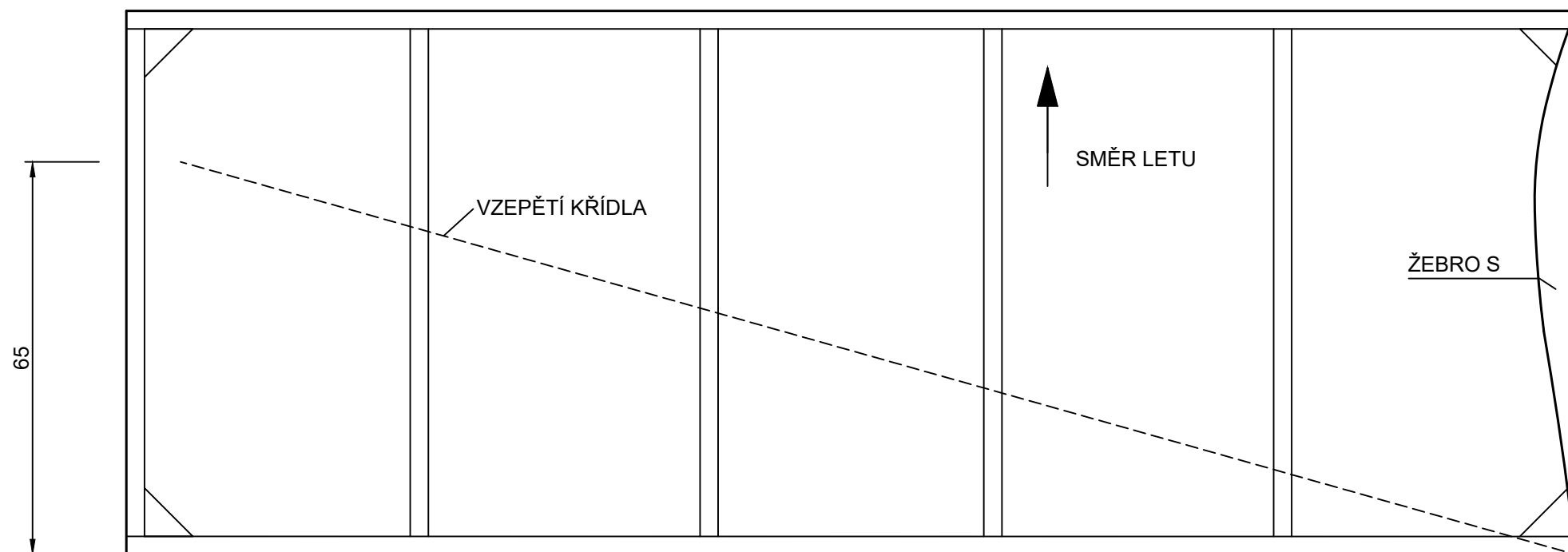
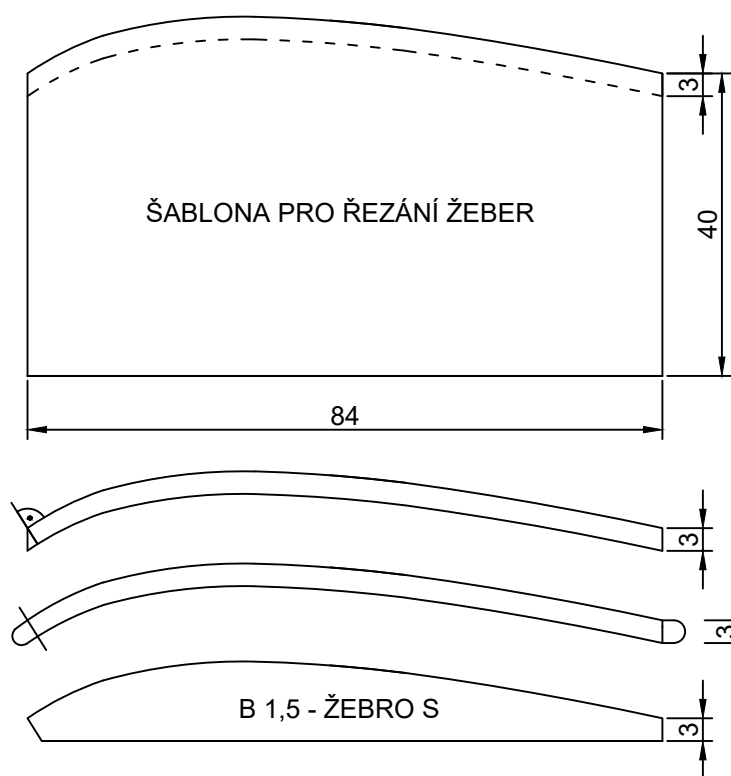

PRAVOTOČIVÁ VRTULE Ø190mm

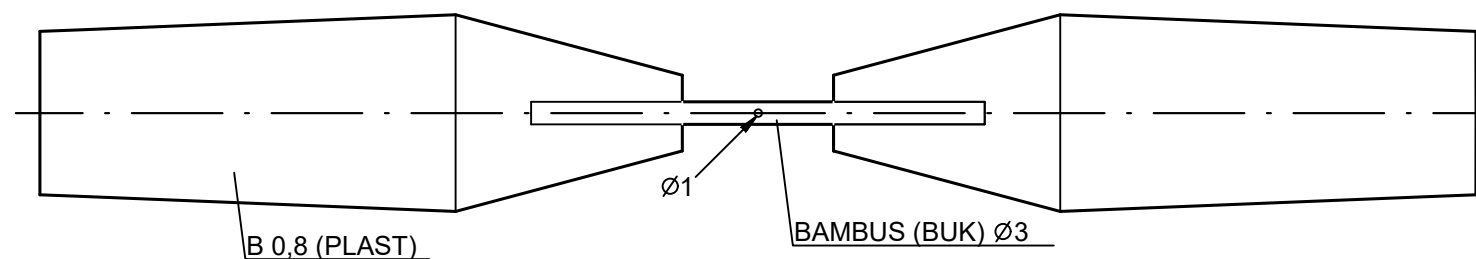

JEPICE

ROZPĚTÍ: 460 mm
 DÉLKA: 380 mm
 HMOTNOST: 18 g



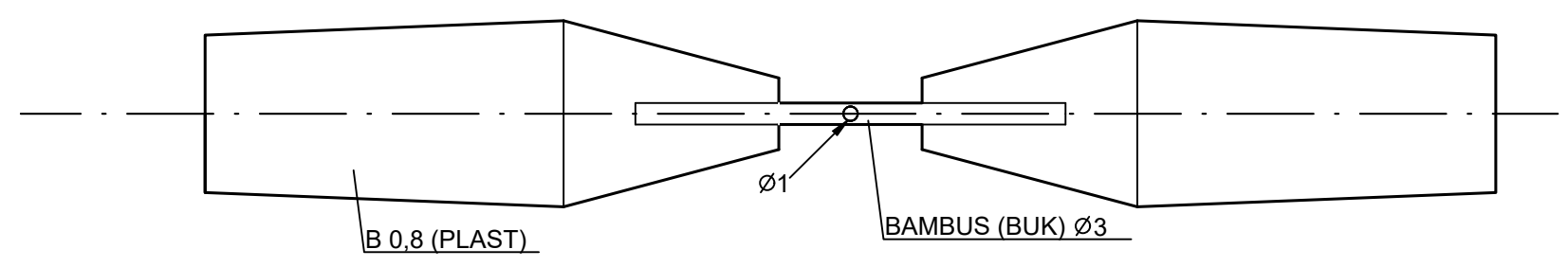
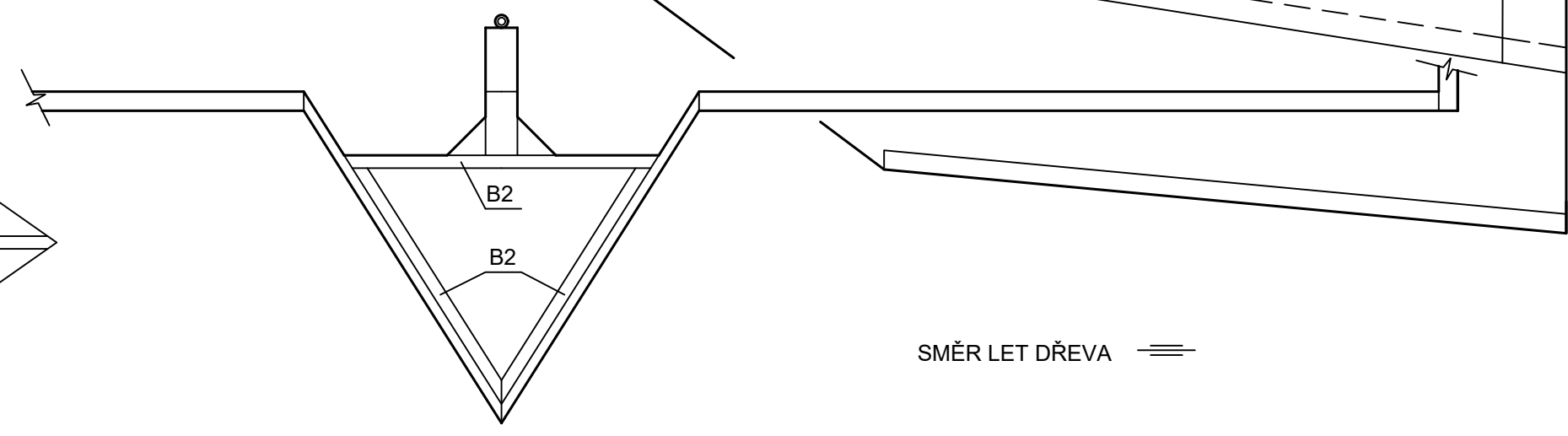
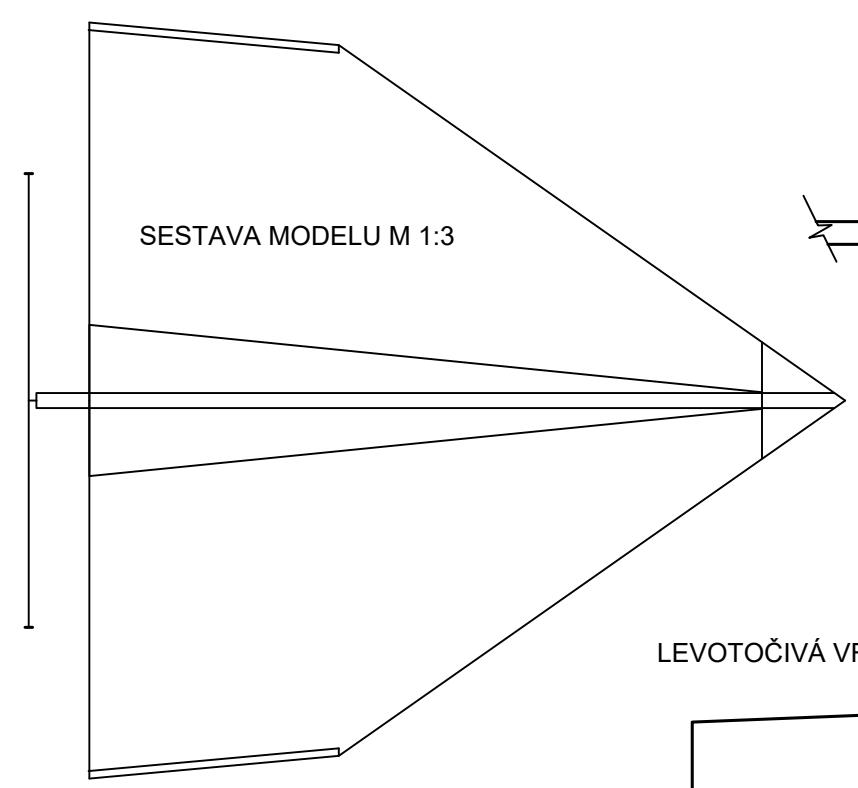
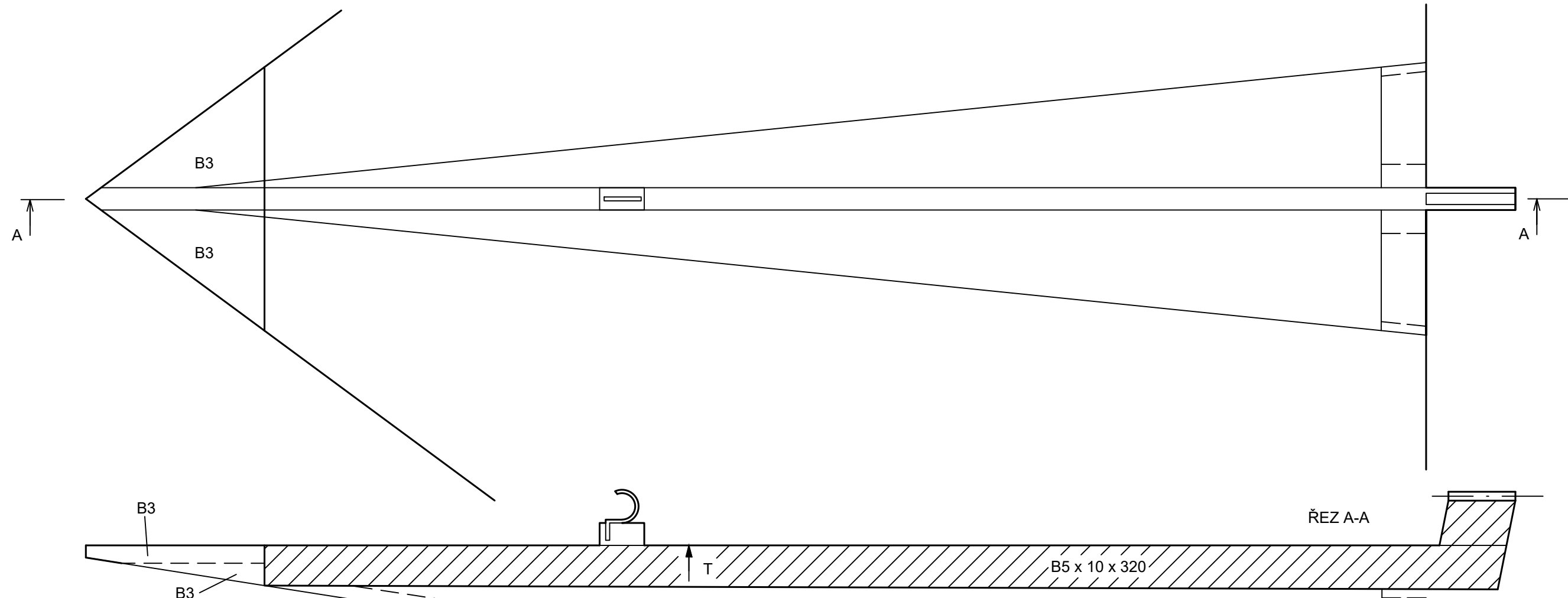

UŠKA
 ROZPĚTÍ: 306 mm
 DÉLKA: 320 mm
 HMOTNOST: 25 g



LIST A

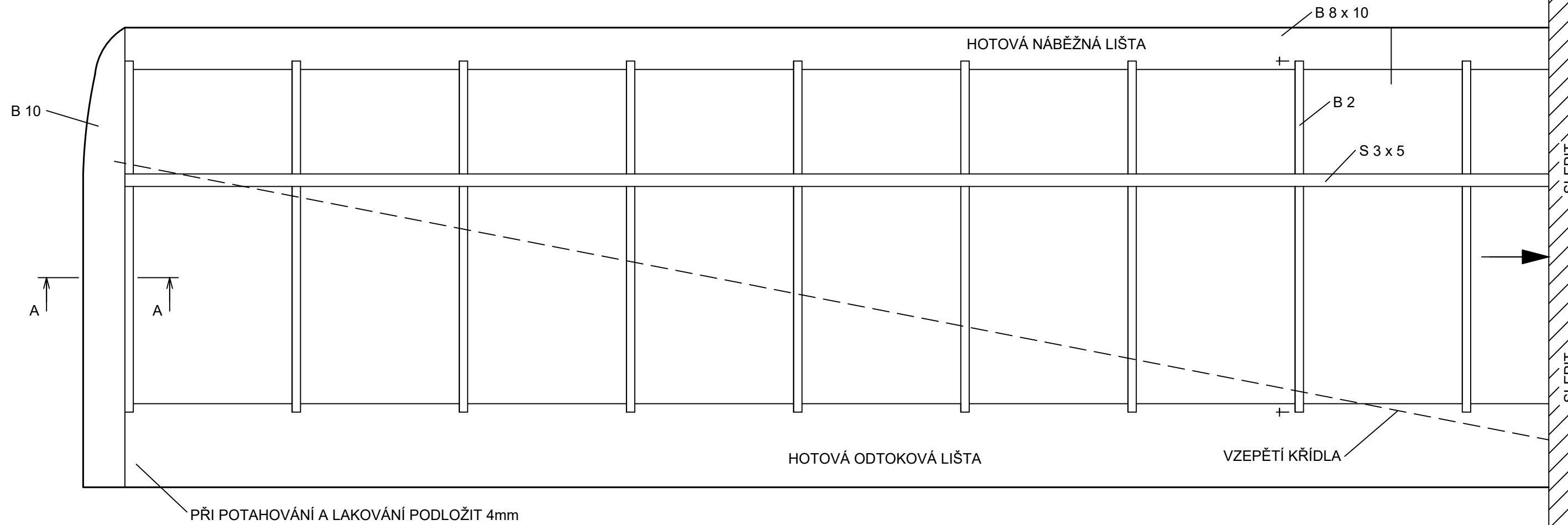
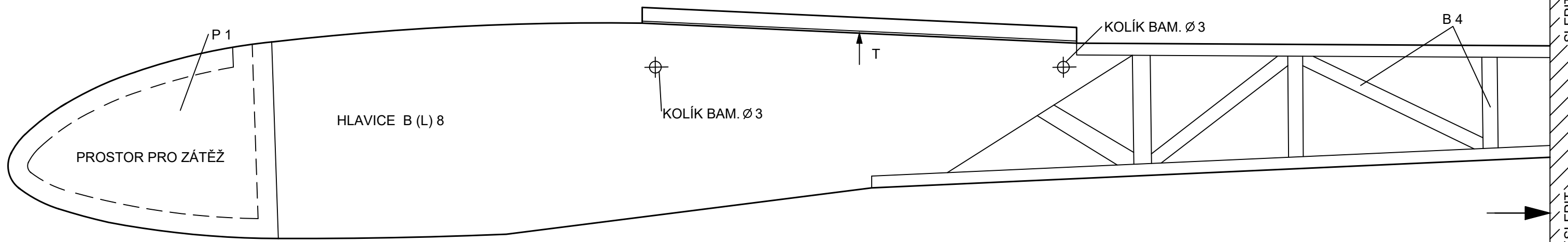
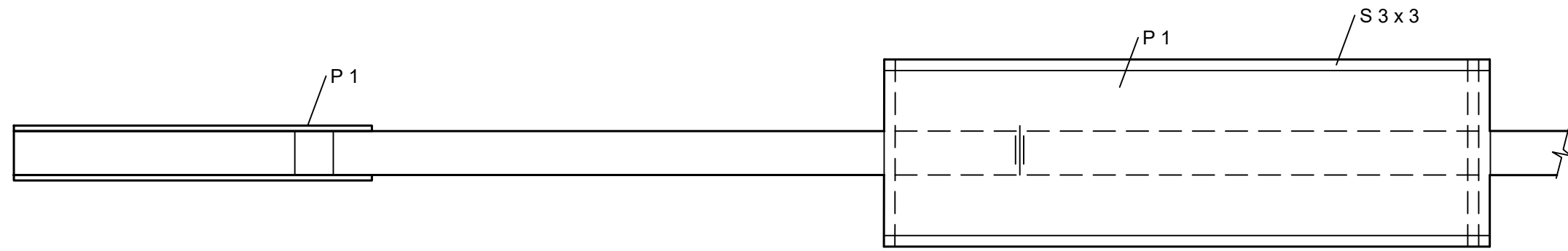

SLEPIT
SLEPIT
SLEPIT
SLEPIT
SLEPIT
SLEPIT
SLEPIT
SLEPIT



POZNÁMKA:
 Ustříhnete čárkovanou část listu B
 a následně nalepte na vyšrafovanou část
 listu A, tak aby se vyznačené šipky přesně
 dotýkaly.

ODSTŘIHNOUT

ODSTŘIHNOUT

ODSTŘIHNOUT

ODSTŘIHNOUT

ODSTŘIHNOUT

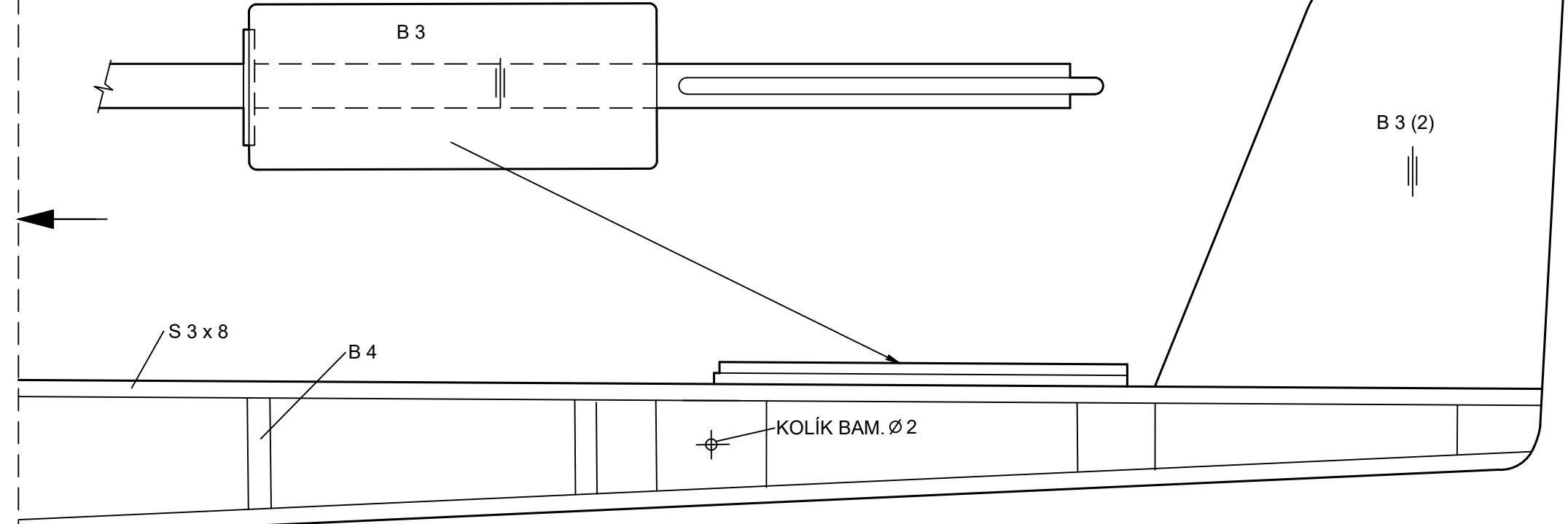

B - Balsa
 S - SMRK
 L - LÍPA
 BAM. - BAMBUS
 SMĚR LET DŘEVA

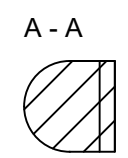
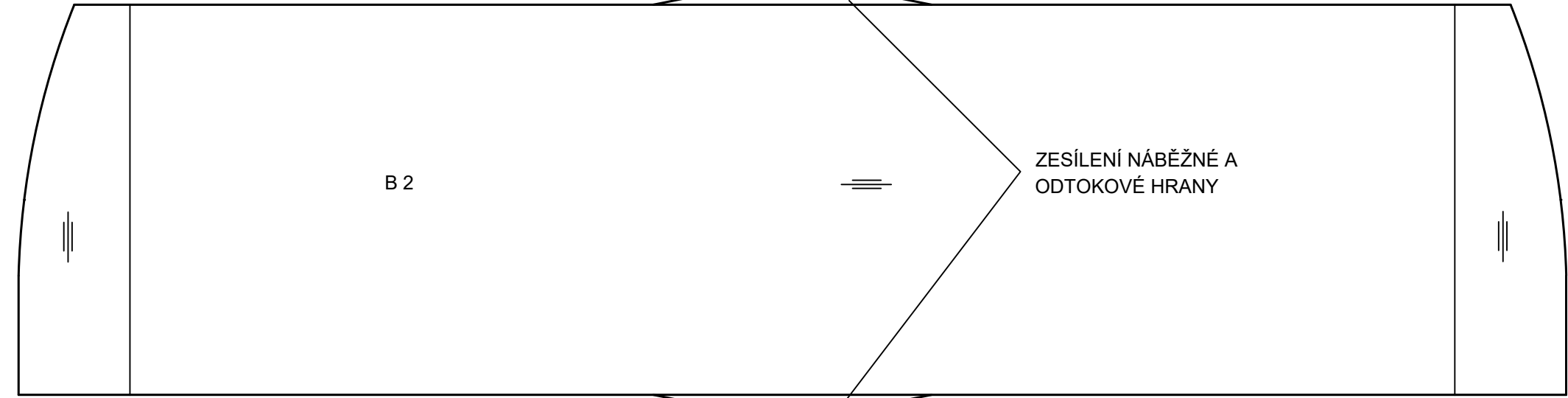
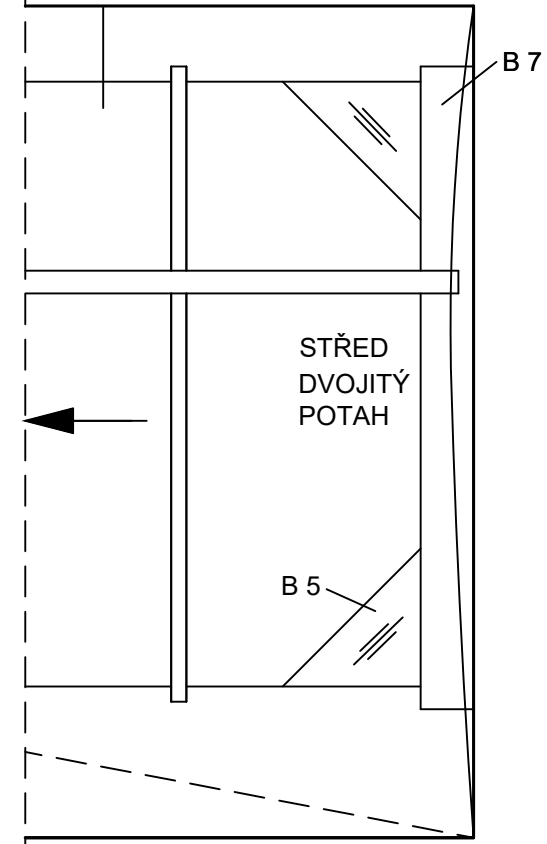

FRÉDA

ROZPĚTÍ: 800 mm
 DÉLKA: 670 mm
 HMOTNOST: 100 g



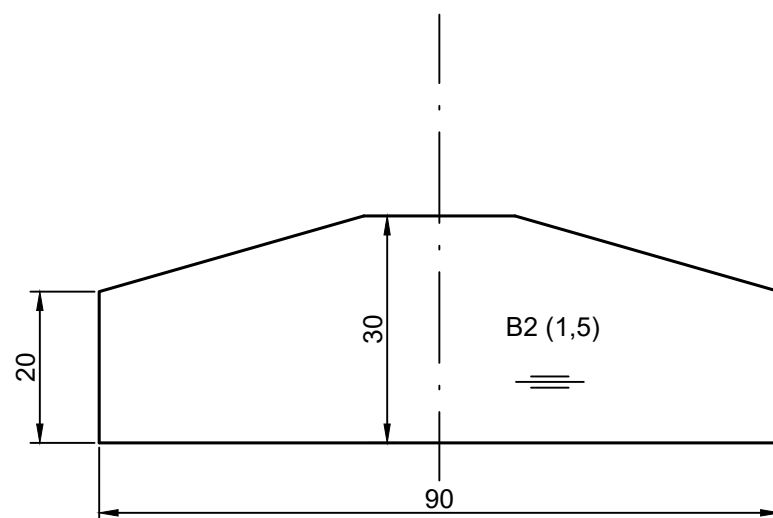
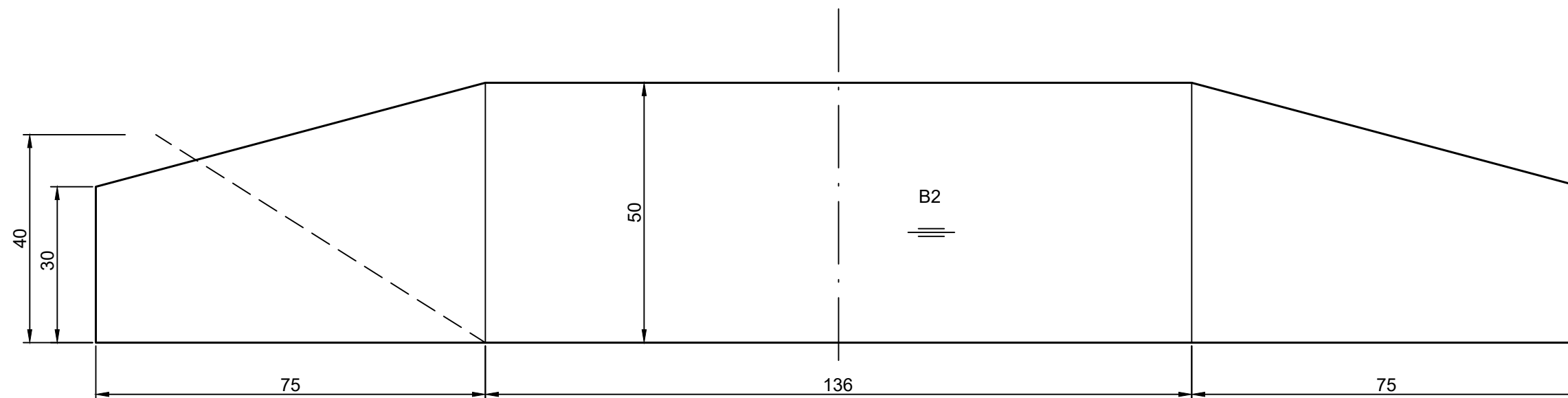
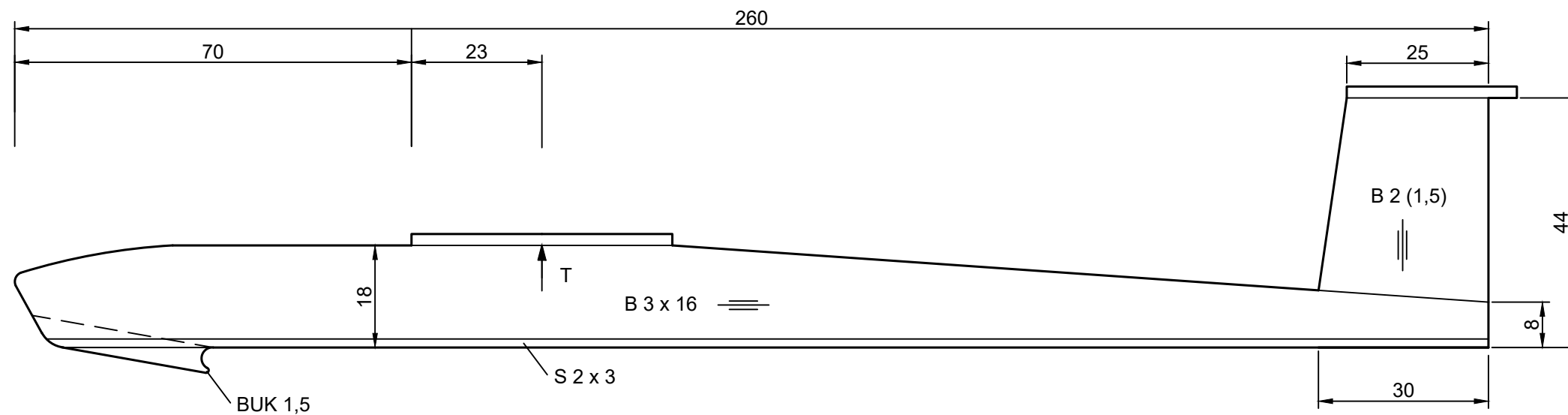

VYSTŘELOVÁK

ROZPĚTÍ: 263 mm
 DÉLKA: 260 mm
 HMOTNOST: 14 g

